

## Screw-In Armatures

for conductivity measuring cells made of plastic

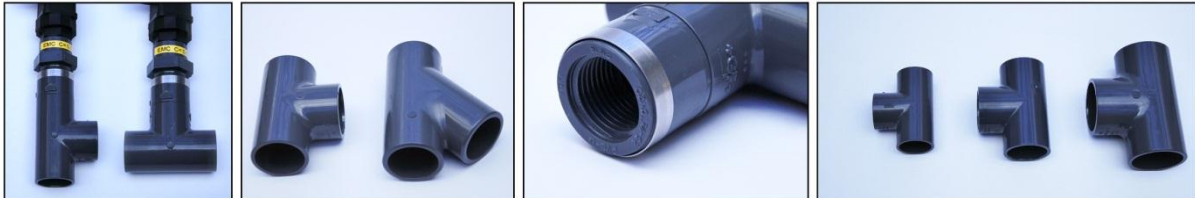

The screw-in armatures serve as housing and protection for conductivity measuring cells in a stationary installable armature. The three different available types can be individually adjusted to the specific task and conditions. Thus, in all fields of industrial process technology, monitoring and laboratory applications universal and accurate measurements are available with a long lasting reliability.

### Features

- for installation in pipework as well as mounting at tanks
- suitable for conductivity measuring cell type EMC, EMC-2, EMU and EMJ
- high operational reliability
- universally applicable at temperatures up to +50 °C
- robust, ready-to-install design
- easy installation and handling
- no utilisation of PVC-damaging thread sealing pastes
- modification to the stated standard installation dimensions on request

### Application fields

- preferred application in water treatment, water purification and exhaust air cleaning plants
- suitable for general industrial measurements

## Technical data

Parameter		Type A	Type B	Type C
number of mountable electrodes		1		
material		PVC		
connection pipework	EMC	D25 / D32	D25 / D32	D25 / D32
	EMC-2	D25 / D32	D25 / D32	D25 / D32
	EMG	D40	D40	D40
	EMJ	D32 / D40	D25 / D32 / D40	D25 / D32 / D40
permitted temperature range		0 to +50 °C		
max. permitted pressure		2 bar		

## Dimensions

Measuring cell	G (thread)	S (mm)	Type	D (mm)	L1 (mm)	L2 (mm)	max. Installation Length L (mm)
EMC	½"	SW32	A	25	19	66	65
	½"	SW32	B	25	19	66	-
	½"	SW32	C	25	19	83	77
	¾"	SW36	A	32	22	78	77
	¾"	SW36	B	32	22	78	-
	¾"	SW36	C	32	22	99	93
EMC-2	½"	SW32	A	25	19	66	65
	½"	SW32	B	25	19	66	-
	½"	SW32	C	25	19	83	77
	¾"	SW36	A	32	22	78	77
	¾"	SW36	B	32	22	78	-
	¾"	SW36	C	32	22	99	93
EMG	1"	SW45	A	40	26	98	94
	1"	SW45	B	40	26	98	-
	1"	SW45	C	40	26	118	102
EMJ	½"	SW36	B	25	19	66	-
	½"	SW36	C	25	19	83	77
	¾"	SW36	A	32	22	78	77
	¾"	SW36	B	32	22	78	-
	¾"	SW36	C	32	22	99	93
	1"	SW36	A	40	26	98	94
	1"	SW36	B	40	26	98	-
	1"	SW36	C	40	26	118	102

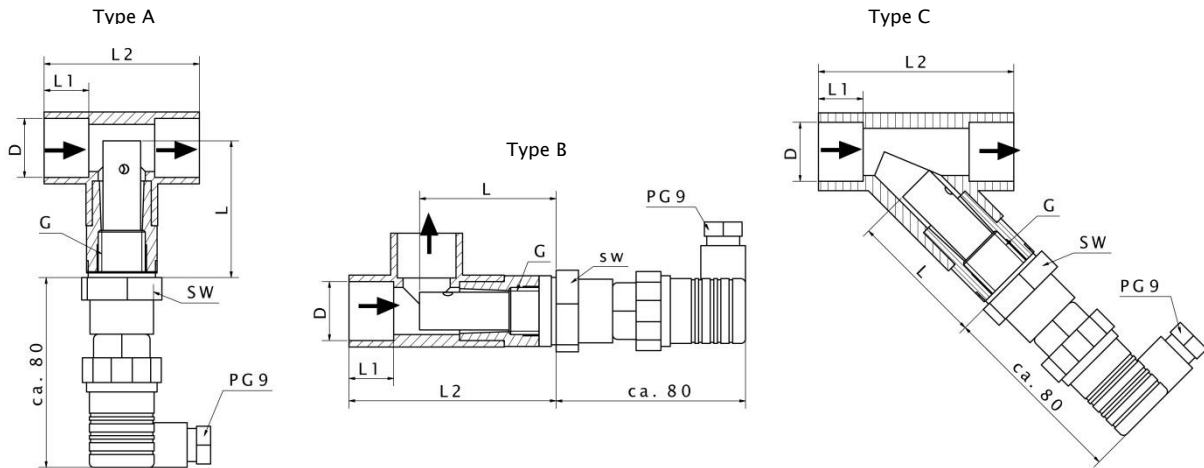

We will be pleased to assist you by selecting the suitable options that meet your requirements. In addition to the displayed order options special customized designs are certainly possible. Please contact us!

The suitable conductivity measuring cells can be found in the respective technical data sheets.

Specifications are subject to modifications.